

Appendix: Trigonometry Basics

This Appendix gives supplementary material on degree measure and right triangle trigonometry. It can be used in connection with Section 8.1.

Degree Measure

One complete revolution of a circle is divided into 360 equal parts, and each part is called a **degree**. Talking about “small parts of a rotation” is awkward, so we call partial rotations **angles**. The measure of an angle is described by the amount of rotation in the turn. For example, a 90-degree angle is one-fourth of a complete counter-clockwise revolution. (See Figure A.1.) A small circle as a superscript is used as a symbol to indicate degrees (90°).

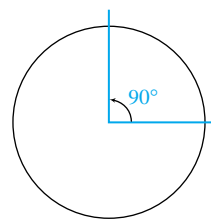

A 90° angle is $\frac{1}{4}$ of a complete revolution

FIGURE A.1

Degree Measurement

$$360 \text{ degrees} = 360^\circ = 1 \text{ complete revolution}$$

$$1 \text{ degree} = 1^\circ = \frac{1}{360} \text{ of a complete revolution}$$

The selection of 360 as the number of divisions is rooted in history and may reflect the fact that the Earth completes one revolution about the sun in approximately 365 days. Because 365 does not have a large number of divisors (only 5 and 73), the inventors of the system probably picked 360 with its multitude of divisors (2, 3, 4, 5, 6, 8, 9, 10, 12, 15, 18, 20, 24, 30, 36, 40, 45, 60, 72, 90, 120, and 180) as being close to the number of days of the year and easy to use in computing. That fortunate choice gives us a large number of even-degree angles that are simple fractions of a full revolution.¹

EXAMPLE 1 *Measuring Angles in Degrees*

- Express $\frac{1}{8}$ of a complete rotation in degrees.
- Express $\frac{1}{3}$ of a complete rotation in degrees.

1. It is possible to divide one revolution into 400 equal parts. Incidentally, some do. These parts are called *gradians* or *grads*, and this angle measure is available on many calculators. Of course, you might prefer to be especially patriotic and divide one revolution into 1776 equal parts. In this case, you would be inventing a new angle measure.

Solution Keeping in mind that one complete rotation is 360° , we have

- a. $\frac{1}{8}(360^\circ) = 45^\circ$ (See Figure A.2a)
 b. $\frac{1}{3}(360^\circ) = 120^\circ$ (See Figure A.2b)

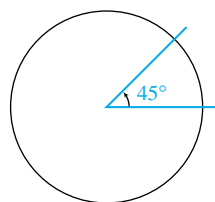

(a)

$\frac{1}{8}$ of a revolution
is a 45° angle

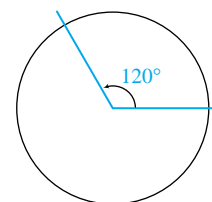

(b)

$\frac{1}{3}$ of a revolution
is a 120° angle

FIGURE A.2

In the study of trigonometry, we consider revolutions around a particular circle. Specifically, we consider the **unit circle**—that is, the circle with radius 1, centered at the origin. We say that an angle is in **standard position** when the vertex of the angle is at the origin and one of its sides is drawn along the positive x -axis. The side that is drawn on the positive x -axis is called the **initial side**. The other side of the angle is called the **terminal side**. Refer to Figure A.3.

Figure A.4 shows a 90° angle, a 160° angle, and a 250° angle.

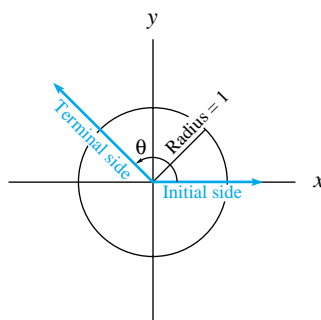

FIGURE A.3

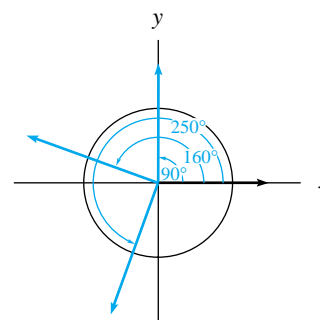

FIGURE A.4

Because a 90° angle is one-quarter of a rotation (one quarter of the way around the full circle), a 180° angle would be one-half of a rotation, a 270° angle would be three-quarters of a rotation, and a 360° angle is one full rotation. Note that in Figure A.4, the 160° angle is drawn between a quarter rotation and a half rotation, and the 250° angle is drawn between a half rotation and a three-quarters rotation. You should also note that all of the rotations are drawn in the counterclockwise direction. We consider a positive angle to define counterclockwise rotation and a negative angle to define clockwise rotation. For example, Figure A.5 illustrates a -90° angle and a -200° angle.

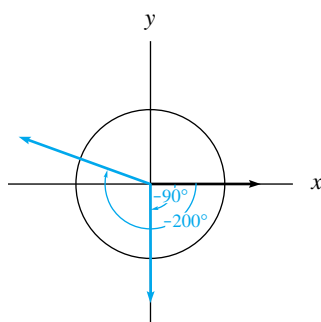

FIGURE A.5

When angle measures are larger than 360° , they describe more than one rotation around the circle. For example, an 810° angle describes two full rotations plus one-quarter of a rotation in the counterclockwise direction ($2 \times 360 + 90 = 810$). A -505° angle describes one full rotation plus one-quarter of a rotation plus an extra -55° angle in the clockwise direction ($-360 - 90 - 55 = -505$). These two angles are shown in Figure A.6.

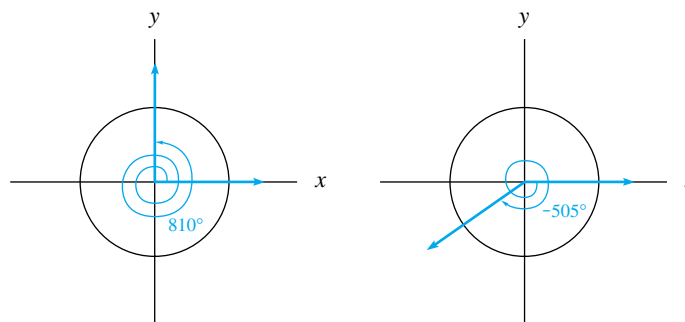

FIGURE A.6

Before defining trigonometric functions for angles on a unit circle, we take a brief look at the trigonometric functions defined in terms of a right triangle.

Right-Triangle Trigonometry

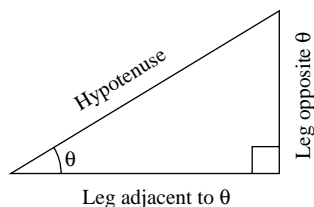

FIGURE A.7

From the early use of trigonometry (meaning “triangle measurement”) through present-day applications, right triangles have provided a method for solving problems that involve indirect measurements. A right triangle is a triangle with one 90° angle. In applications, we generally label one of the remaining angles of the right triangle as angle θ . (See Figure A.7.)

We define the **sine** of the angle θ as the ratio of the length of the leg opposite the angle to the length of the hypotenuse (the side opposite the right angle). The **cosine** of the angle θ is the ratio of the length of the adjacent leg to the length of the hypotenuse. The **tangent** of the angle θ is the ratio of the length of the leg opposite the angle θ to the length of the adjacent leg. We abbreviate cosine θ by $\cos \theta$, sine θ by $\sin \theta$, and tangent θ by $\tan \theta$.

Right-Triangle Trigonometric Definitions

For a right triangle with one of the non- 90° angles having measure θ , the sine, cosine, and tangent of θ are defined in terms of the sides of the triangle.

$$\sin \theta = \frac{\text{length of the leg opposite the angle } \theta}{\text{length of the hypotenuse}}$$

$$\cos \theta = \frac{\text{length of the leg adjacent to the angle } \theta}{\text{length of the hypotenuse}}$$

$$\tan \theta = \frac{\text{length of the leg opposite the angle } \theta}{\text{length of the leg adjacent to the angle } \theta}$$

These three functions are illustrated in Figure A.8.

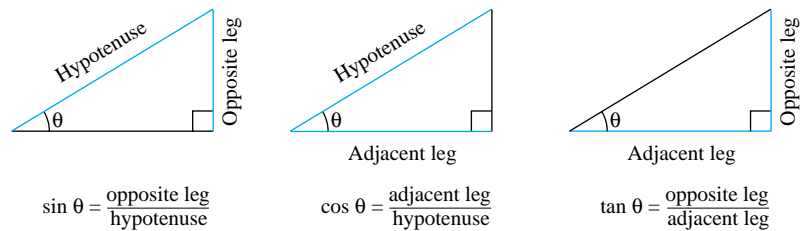

FIGURE A.8

Three other functions that are commonly studied in trigonometry are the secant, cosecant, and cotangent functions. They are defined in terms of the first three trigonometric functions as follows:

$$\begin{aligned} \text{secant } \theta: \quad \sec \theta &= \frac{1}{\cos \theta} = \frac{\text{length of the hypotenuse}}{\text{length of the adjacent leg}} \\ \text{cosecant } \theta: \quad \csc \theta &= \frac{1}{\sin \theta} = \frac{\text{length of the hypotenuse}}{\text{length of the opposite leg}} \\ \text{cotangent } \theta: \quad \cot \theta &= \frac{1}{\tan \theta} = \frac{\text{length of the adjacent leg}}{\text{length of the opposite leg}} \end{aligned}$$

We study primarily $\sin \theta$, $\cos \theta$, and $\tan \theta$ because the other three trigonometric functions are defined in terms of them.

If we are given any right triangle for which we know the angle θ and know the length of one side of the triangle, we can use the trigonometric functions $\sin \theta$, $\cos \theta$, and $\tan \theta$ to obtain the lengths of the other two sides of the triangle. For example, if we have a right triangle with a 25° angle and hypotenuse of length 2 inches, we can use $\sin 25^\circ$ and $\cos 25^\circ$ to find the lengths of the two legs. (See Figure A.9.)

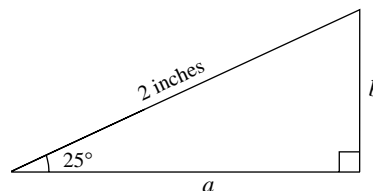

FIGURE A.9

To find the length of the leg adjacent to the 25° angle, we use the fact that $\cos 25^\circ$ is the ratio of the length of the adjacent leg to the length of the hypotenuse. We will use a to represent the length of the adjacent leg, so $\cos 25^\circ = \frac{a}{2}$. Solving for a , we have

$$a = 2 \cos 25^\circ \approx 2(0.90631) \approx 1.81262 \text{ inches}$$



That is, the leg adjacent to the 25° angle is approximately 1.8 inches long. Similarly, the length of side b can be found as

$$b = 2 \sin 25^\circ \approx 2(0.42262) \approx 0.84524 \text{ inch}$$

Trigonometry is often used in applications where indirect measurement of the length of one or more legs of a triangle is necessary. Land surveying often relies on the use of an instrument called a sextant to measure angles and on trigonometry to determine distances using right triangles.

EXAMPLE 2 *Castle Measurement*

A soldier in ancient times making use of triangle ratios is illustrated in Figure A.10. He is using a sextant and sighting it in line with the top of the castle wall. The sextant gives an angle of 14.6° . The soldier then counts the bricks in the wall and estimates the distance d without having to enter the battle zone between his safe spot and the castle wall.

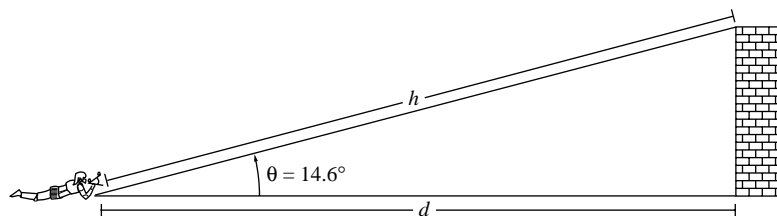

FIGURE A.10

- Estimate the height of the wall if each brick is 11 inches tall.
- Find the distance to the castle.
- Find the distance from the soldier to the top of the castle wall.

Solution

- There are 22 layers of bricks in the wall, so the wall is (22 bricks)(11 inches per brick) = 242 inches \approx 20.2 feet tall.
- Using the definition of the tangent of an angle, we know that

$$\tan 14.6^\circ \approx \frac{20.2 \text{ feet}}{d}$$

so we have

$$d \approx \frac{20.2 \text{ feet}}{\tan 14.6^\circ} \approx \frac{20.2 \text{ feet}}{0.26048} \approx 77.4 \text{ feet}$$

The soldier is approximately 77.4 feet away from the castle.

- The Pythagorean Theorem yields

$$h \approx \sqrt{20.2^2 + 77.4^2} \approx \sqrt{6400.7} \approx 80 \text{ feet}$$

The soldier is approximately 80 feet away from the top of the castle wall.

Two special right triangles that occur in applications using trigonometry are the **30° – 60° right triangle** and the **45° – 45° right triangle**. The values of sine, cosine, and tangent for one of these triangles are explored in the next example. The other triangle is left for an activity.

EXAMPLE 3 *Ratios for a Special Triangle*

The 30° – 60° right triangle is so named because in a right triangle with a 30° angle, the remaining angle must be 60° . A reflection of the triangle across the leg between

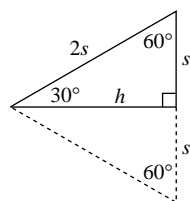

FIGURE A.11

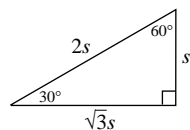

FIGURE A.12

the 30° angle and the right angle forms an equilateral triangle (one whose three sides are of equal length). The line of reflection is the perpendicular bisector of the base. (See Figure A.11.)

- Use the Pythagorean Theorem to find the length h in terms of s .
- Use the sides h and s to find the sine, cosine, and tangent for the 30° angle in a 30°–60° right triangle.
- Use the sides h and s to find the sine, cosine, and tangent for the 60° angle.

Solution

- The side opposite the 30° angle has length s that is equal to half of the length $2s$ of the hypotenuse. Applying the Pythagorean Theorem yields

$$h^2 + s^2 = (2s)^2$$

Solving for h , we find the remaining leg length to be

$$h = \sqrt{(2s)^2 - s^2} = \sqrt{4s^2 - s^2} = \sqrt{3s^2} = \sqrt{3}s$$

- Referring to Figure A.12, we find the values of sine, cosine, and tangent for the 30° angle in the right triangle.

$$\sin 30^\circ = \frac{s}{2s} = \frac{1}{2}$$

$$\cos 30^\circ = \frac{\sqrt{3}s}{2s} = \frac{\sqrt{3}}{2}$$

$$\tan 30^\circ = \frac{s}{\sqrt{3}s} = \frac{1}{\sqrt{3}}$$

- Similarly, the values of sine, cosine, and tangent for the 60° angle follow.

$$\sin 60^\circ = \frac{\sqrt{3}s}{2s} = \frac{\sqrt{3}}{2}$$

$$\cos 60^\circ = \frac{s}{2s} = \frac{1}{2}$$

$$\tan 60^\circ = \frac{\sqrt{3}s}{s} = \sqrt{3}$$

.....

Unit-Circle Trigonometry

Right-triangle trigonometry is useful in many applications. However, as we previously noted, the trigonometric functions are not restricted to use with angles that are less than 90°.

We can now define the trigonometric functions sine, cosine, and tangent for all angles by referring to our knowledge of right-triangle trigonometry. When the angle θ is between 0° and 90°, we draw a right triangle in the unit circle such that the hypotenuse of the triangle is along the terminal side of the angle θ from the origin to the unit circle, and the other two legs of the right triangle are drawn along the x -axis and perpendicular to the x -axis, as shown in Figure A.13.

If we let (x, y) represent the point where the terminal edge of angle θ intersects the unit circle, then the leg drawn along the x -axis has length x and the leg drawn perpendicular to the x -axis has length y . The hypotenuse has length 1 (the radius of the

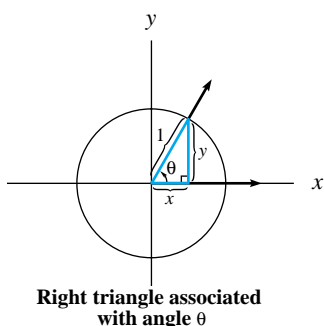

FIGURE A.13

unit circle). We define the trigonometric functions $\sin \theta$, $\cos \theta$, and $\tan \theta$ as we did for the right triangle, so that

$$\sin \theta = \frac{y}{1} = y$$

$$\cos \theta = \frac{x}{1} = x$$

$$\tan \theta = \frac{y}{x}$$

We define the trigonometric functions similarly for angles that are not between 0° and 90° . First, draw the angle on the unit circle. Then draw a right triangle such that the hypotenuse of the triangle is along the terminal side of the angle θ from the origin to the unit circle, and the other two legs of the right triangle are drawn along the x -axis (possibly in the negative x direction) and perpendicular to the x -axis (possibly in the negative y direction) as shown in Figures A.14a and b.

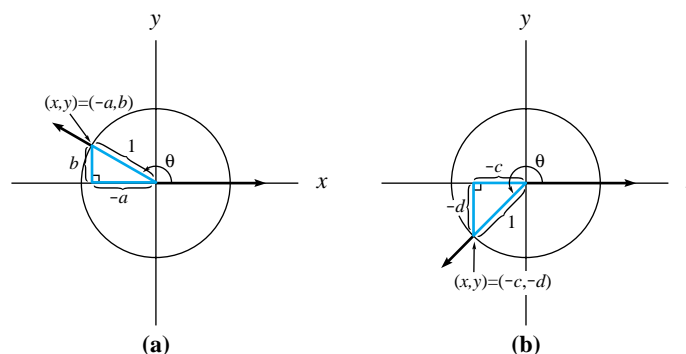

FIGURE A.14

Once again, call the point where the terminal edge of angle θ intersects the unit circle (x, y) , and let a represent the length of the leg drawn along the x -axis and let b represent the length of the leg drawn perpendicular to the x -axis. The hypotenuse has length 1 (the radius of the unit circle). However, we must indicate whether the legs of the triangle are drawn in the negative x and/or the negative y direction. We indicate this by writing the negative of the length in the appropriate direction. For example, the triangle in Figure A.14a has one leg along the negative portion of the x -axis. This leg has length a in the negative x direction, so $x = -a$. The other leg is drawn up from the x -axis; thus it has positive direction and has length $y = b$.

We define the trigonometric functions $\sin \theta$, $\cos \theta$, and $\tan \theta$ as we have done previously, so that $\sin \theta = \frac{y}{1} = y$, $\cos \theta = \frac{x}{1} = x$, and $\tan \theta = \frac{y}{x}$. Thus, for the angle drawn in Figure A.14a, $\sin \theta = b$, $\cos \theta = -a$, and $\tan \theta = \frac{b}{-a} = -\frac{b}{a}$. Similarly, for the angle drawn in Figure A.14b, $\sin \theta = -d$, $\cos \theta = -c$, and $\tan \theta = \frac{-d}{-c} = \frac{d}{c}$.

In general, for any angle θ , we define sine, cosine, and tangent as follows:

Unit-Circle Trigonometric Definitions

Let (x, y) be the point on the unit circle where the terminal side of the angle θ intersects the circle. Then the sine, cosine, and tangent of the angle θ are

$$\sin \theta = y$$

$$\cos \theta = x$$

$$\tan \theta = \frac{y}{x}$$

Because the unit circle is given by the equation $x^2 + y^2 = 1$, it is true that for any angle θ , $\cos^2\theta + \sin^2\theta = 1$.

EXAMPLE 4 *Ratios for a Specific Angle*

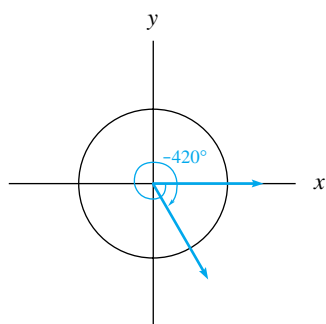

FIGURE A.15

A -420° angle is shown in Figure A.15.

- Draw the right triangle associated with a -420° angle. Label the angle in the triangle between the terminal side and the x -axis.
- Find the sine, cosine, and tangent for a -420° angle.

Solution

a.

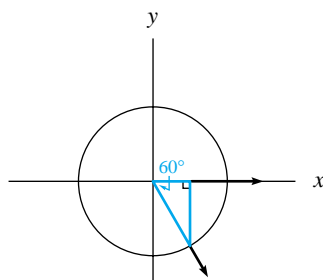

Right triangle associated with the -420° angle

FIGURE A.16

- This right triangle is one of the special triangles mentioned in Example 3. It is a 30° - 60° right triangle. We know from Example 3 that $\sin 60^\circ = \frac{\sqrt{3}}{2}$ and $\cos 60^\circ = \frac{1}{2}$. Thus the leg on the x -axis is positive and has length $\cos 60^\circ = \frac{1}{2}$, so $x = \frac{1}{2}$. The other leg is drawn down from the x -axis, so it is negative and has length $\sin 60^\circ = \frac{\sqrt{3}}{2}$, so $y = -\frac{\sqrt{3}}{2}$. Add these values to the figure of the -420° angle. See Figure A.17. Now we can read the trigonometric values from the figure:

$$\sin(-420^\circ) = y = -\frac{\sqrt{3}}{2}$$

$$\cos(-420^\circ) = x = \frac{1}{2}$$

$$\tan(-420^\circ) = \frac{y}{x} = -\sqrt{3}$$

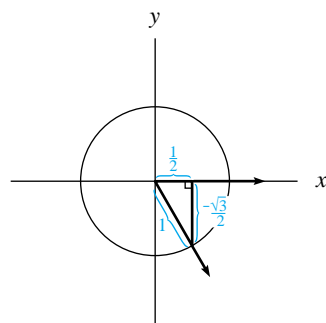
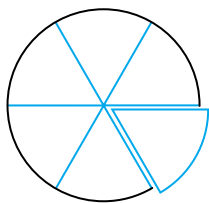

FIGURE A.17

We have now defined trigonometric functions as they apply to right triangles and, in the much broader sense, as they apply to unit circles. However, our discussion of unit-circle trigonometry would not be complete if we did not consider another angle measure called *radian measure*. In fact, we cannot use the trig functions in calculus without considering radian measure of angles.

Radian Measure

We now consider another unit of angle measurement called a *radian*. Picture a circular pizza. We can describe a slice of pizza in terms of the angle of the wedge



$\frac{1}{6}$ of a pizza is a 60° wedge.

FIGURE A.18

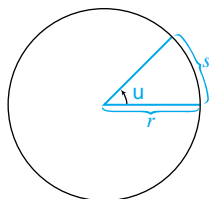

The *radian measure* of an angle is the ratio of the arc length to the radius.

$$\theta = \frac{s}{r}$$

FIGURE A.19

formed by the slice. For instance, in angular terms we would describe one-eighth of a pizza as a 45° wedge. A one-sixth slice would be described as a 60° wedge (see Figure A.18).

Another way to think of a slice of pizza is in terms of the amount of crust around the edge. If there were something special in the crust, like a cheese filling, then we might want to focus on the length of the crust around the circular edge of the slice. In doing so, we would be talking about an arc of a circle—that is, the slice's portion of the circumference. (A portion of the circle is called an *arc*, and the complete distance around the circle is its *circumference*.) If the radius r of the pizza in Figure A.18 were 1 foot, then the circumference of the pizza would be $2\pi r = 2\pi(1 \text{ foot}) = 2\pi$ feet ≈ 6.3 feet. Basic geometry tells us that the arc length is the same fractional part of the circumference of the circle as the angle is of one complete rotation. Thus the 45° wedge would form an arc of $\frac{45^\circ}{360^\circ}(2\pi \text{ feet}) \approx 0.8$ foot of the special cheese crust. The 60° wedge would form an arc of $\frac{60^\circ}{360^\circ}(2\pi \text{ feet}) \approx 1$ foot.

We define the **radian measure** of an angle to be the ratio of the length of the arc s cut out of the circumference of a circle by the angle θ to the radius r of the circle. (See Figure A.19.) Because the total arc length (that is, the circumference) of a circle is 2π times its radius, a full revolution has radian measure of 2π . Note that 2π is a real number approximately equal to 6.283. It is important to recognize that the radian measure of an angle is a real number with no units attached. In the definition of radian measure, both s and r measure length and must have the same units, which causes θ to be a unitless quantity. At first this might seem to be a strange way to measure angles, but we later find that radian measure of angles gives simple calculus results for the trigonometric functions with which we will be dealing.

Radian Measurement

$$2\pi \text{ radians} = 1 \text{ complete revolution}$$

$$1 \text{ radian} = \frac{1}{2\pi} \text{ of a complete revolution}$$

EXAMPLE 5 Measuring Angles in Radians

- Express $\frac{1}{8}$ of a complete rotation in radians.
- Express $\frac{1}{4}$ of a complete rotation in radians.
- Express 4π radians in terms of complete rotations.

Solution Keeping in mind that 1 complete rotation is 2π radians, we have

$$\text{a. } \frac{1}{8}(2\pi) = \frac{\pi}{4} \text{ radians}$$

$$\text{b. } \frac{1}{4}(2\pi) = \frac{\pi}{2} \text{ radians}$$

$$\text{c. Because } 1 \text{ radian} = \frac{1}{2\pi} \text{ of a complete revolution, } 4\pi \text{ radians is } 4\pi\left(\frac{1}{2\pi}\right) = 2 \text{ complete rotations.}$$

The odometer on an automobile converts turns of the drive shaft into distances so that you can observe the number of miles you have traveled. Although the next example explores this idea, it is not unique to automobiles. Whenever wheels rotate to cause movement, the same type of relationship between rotations of the wheels and distance traveled holds true.

EXAMPLE 6 *Rotating Wheels*

Consider a front-wheel-drive automobile with wheels that are 20 inches in diameter.

- How far will 1 rotation of the wheels cause the automobile to travel?
- How many times will the wheels revolve when the automobile travels 1 mile?

Solution

- As an automobile travels, its drive shaft and front tires turn at the same rate; that is, 1 revolution in one causes 1 revolution in the other. If the wheels are 20 inches in diameter (radius = 10 inches), then each rotation causes the automobile to move forward $2\pi r = (2\pi)(10 \text{ inches}) \approx 62.8 \text{ inches} \approx 5.2 \text{ feet}$. Each rotation of the wheels causes the automobile to travel about 62.8 inches or 5.2 feet.
- There are $(5280 \frac{\text{feet}}{\text{mile}})(12 \frac{\text{inches}}{\text{foot}}) = 63,360$ inches in a mile. So

$$\left(63,360 \frac{\text{inches}}{\text{mile}}\right) \left(\frac{1 \text{ revolution}}{2\pi \cdot 10 \text{ inches}}\right) \approx 1008.4 \frac{\text{revolutions}}{\text{mile}}$$

The wheels must revolve approximately 1008.4 times in each mile traveled.

Angle Measure Conversions

Whenever you have two measurement scales that can be applied to the same object, it is important to have a conversion technique. In this case, 1 revolution is both 360° and 2π radians. Thus degrees are converted to radians by multiplying by $\frac{2\pi}{360^\circ} = \frac{\pi}{180^\circ}$, and radians are converted to degrees by multiplying by $\frac{180^\circ}{\pi}$. Our conversion formula is

Angle Conversion Formula

$$\pi \text{ radians} = 180^\circ$$

Up to this point, we have used the word *radian* to specify our choice of angle measure, *not* the units of the angle. You may have noted that it is cumbersome to write the word *radians* each time angle measure is used. Therefore, we adopt the following convention.

Angle Measure Convention

All angles are understood to be measured in radians unless the degree symbol is used to specify degree measure of the angle.

That is, an angle with measure 60 is quite different than one with measure 60°. An angle of 60 radians is more than 9 full revolutions, whereas an angle of 60° is only one-sixth of a revolution. If you mean an angle of 60 degrees, be certain that you use the degree symbol with the angle.

EXAMPLE 7 *Converting Angles*



- a. Express $\frac{7\pi}{6}$ in degrees.
- b. Express 135° in radians.

Solution

- a. $\frac{7\pi}{6} = \left(\frac{7\pi}{6}\right)\left(\frac{180^\circ}{\pi}\right) = 210^\circ$
- b. $135^\circ = (135^\circ)\left(\frac{\pi}{180^\circ}\right) = \frac{3\pi}{4}$

Only radian measure of angles is used in Chapter 8 of this text because our purpose is to apply calculus to trig functions. The definitions for the trig functions given in this Appendix coincide with the definition given in Section 8.1.

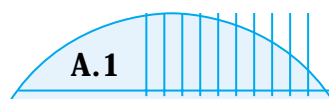

Concept Inventory

- *Degree measure of angles*
- *Initial and terminal sides and standard position of angles*
- *Right-triangle trigonometry: sine, cosine, and tangent*
- *Unit-circle trigonometry: sine, cosine, and tangent*
- *Radian measure of angles*
- *Angle measure conversion*



Activities

1. Because the number 360 has so many integer divisors, many fractional revolutions have nice expressions when expressed as angles measured in degrees. Complete Table A.1 of fractional rotations or full rotations and their associated degree measures.
2. There are many easily expressed fractions of a full turn, and the measure of these expressions in radians is easy to determine. Complete Table A.2 of

TABLE A.1

| | | | | | | |
|----------------------------|----------------|----------------|------|---------------|---------------|---------------|
| Rotation (in turns) | $\frac{1}{24}$ | $\frac{1}{12}$ | | | $\frac{1}{4}$ | $\frac{1}{3}$ |
| Angle measure (in degrees) | 15° | | 45° | 60° | | 120° |
| Rotation (in turns) | $\frac{3}{8}$ | $\frac{1}{2}$ | | $\frac{2}{3}$ | | $\frac{5}{6}$ |
| Angle measure (in degrees) | 135° | 180° | 225° | 240° | 270° | 300° |
| Rotation (in turns) | $\frac{7}{8}$ | 1 | | 3 | | 60 |
| Angle measure (in degrees) | | | 720° | | 3780° | |

TABLE A.2

| | | | | | | |
|----------------------------|------------------|----------------|------------------|-----------------|------------------|------------------|
| Rotation (in turns) | $\frac{1}{24}$ | $\frac{1}{12}$ | | | $\frac{1}{4}$ | $\frac{1}{3}$ |
| Angle measure (in radians) | $\frac{\pi}{12}$ | | $\frac{\pi}{4}$ | $\frac{\pi}{3}$ | | |
| Rotation (in turns) | $\frac{3}{8}$ | $\frac{1}{2}$ | | $\frac{2}{3}$ | | $\frac{5}{6}$ |
| Angle measure (in radians) | | π | $\frac{5\pi}{4}$ | | $\frac{3\pi}{2}$ | $\frac{5\pi}{3}$ |
| Rotation (in turns) | $\frac{7}{8}$ | 1 | | 3 | | 60 |
| Angle measure (in radians) | | | 4π | | 10.5π | |

- fractional rotations or full rotations and their associated radian measures.
- Convert the following angles in degrees into angles in radians, and sketch the angles on a unit circle.
 - 110°
 - 700°
 - 90°
 - 0.01°
 - Convert the following angles in radians to angles in degrees, and sketch the angles on a unit circle.
 - 2π
 - $\frac{3\pi}{8}$
 - $\frac{7\pi}{16}$
 - 30
 - Superbike II, the \$15,000 baby of the U.S. Cycling Federation (USCF), made its debut in the 1996 Olympics. Superbike II's front wheel is 23.62 inches in diameter, and its rear wheel is 27.56 inches in diameter. Over a distance of 1 mile, how many turns does each wheel make?
 - Use degree measure to write the angle that the tenths wheel on the odometer turns when the drive shaft of the automobile in Example 6 completes one turn.
 - If there are 30 equally spaced seats on a Ferris wheel, through what angle does the wheel move between stops to release passengers in two consecutive seats?
 - What is the radian measurement of this angle?
 - If the Ferris wheel is 100 feet in diameter, what is the distance traveled by each of the seats as the operator stops between consecutive seats to exchange passengers?
 - If the owner of the automobile in Example 6 replaced the tires with oversized tires that were 22 inches in diameter, what would be the error created on the odometer readings?
 - If the tires were replaced with tires that have an 18-inch diameter, what would be the error caused on the odometer?
 - If the regular tires (20-inch diameter) lost 0.001 inch of their diameter through wear, how would the odometer readings be affected?
 - For finer measurements, the degree is further divided into 60 parts, and each such part is called a **minute**. The symbol used to indicate minutes is the single prime; for example, 15 minutes is expressed as $0^\circ 15'$. An angle consisting of 200 minutes could also be expressed as $3^\circ 20'$. For even finer measurements, the minute is further divided into 60 equal parts called **seconds**. The symbol for a second is the double prime, so an angle of 30 degrees 14 minutes 7 seconds would be written as $30^\circ 14' 7''$. You might try to estimate how small a second is to realize how much precision is used when some jobs state acceptable tolerances in terms of a seconds of arc.² Convert into decimal degree equivalents the following angles given in degrees, minutes, and seconds.
 - $5^\circ 30' 30''$
 - $35^\circ 12' 17''$
 - Refer to the definitions in Activity 9, and convert into measures using degrees, minutes, and seconds the following angles given in decimal degrees.
 - 5.1234°
 - 125.365°
 - The Saturn missile used in the moon shots had guidance computers placed on a stable gimbale platform that had to stay within 4 seconds of arc for the first 15 minutes of the launch.

11. Suppose you were to divide a rotation into 1776 pieces. We will call each piece a “patriotic unit” and will use the abbreviation PU.
- How many rotations does each of the following patriotic unit measurements represent?
 - 1776 PU
 - 1332 PU
 - 888 PU
 - 444 PU
 - 222 PU
 - 111 PU
 - Convert each of the patriotic unit measurements in part a to radians.
 - Find the value of each of the following:
 - $\cos(1776 \text{ PU})$
 - $\sin(1776 \text{ PU})$
 - $\cos(666 \text{ PU})$
 - $\sin(666 \text{ PU})$
12. Creating different angle measurement systems such as degrees and grads for partial turns and calculating their conversion factors is like making a 25-hour clock. Mr. Morton Rachofsky has built a 25-hour clock for the Circadian Clock Company.³ This clock divides the 86,400 seconds in the standard day into 25 equal-length periods called “hours.” Noon on the clock is the same as noon on our regular time scale, but the other hour marks are different. Scientists conducting experiments in the 1930s observed people in caves where they could not see the sun. These people developed activity cycles that lasted 25 hours. Because we cannot change the solar day, Mr. Rachofsky said, “Why not change the clock?”
- How long are Mr. Rachofsky “hours” in our regular minutes?
 - What time on Mr. Rachofsky’s clock is the regular clock time 3:00 p.m.?
 - What is the regular clock time when it is 6:00 p.m. on Mr. Rachofsky’s clock?

For Activities 13 through 18, identify the trigonometric function you would use to find the length of the indicated side. Assume that the triangle given is a right triangle with one of the other two angles identified as angle θ .

- Given the length of the hypotenuse, find the length of the leg adjacent to angle θ .
 - Given the length of the leg opposite angle θ , find the length of the leg adjacent to angle θ .
 - Find the length of the leg opposite angle θ , given the length of the leg adjacent to angle θ .
 - Find the length of the hypotenuse, given the length of the leg opposite angle θ .
 - Given the length of the leg adjacent to angle θ , find the length of the hypotenuse.
 - Given the length of the hypotenuse, find the length of the leg opposite angle θ .
- For Activities 19 through 24, solve for the length of the indicated side. Assume that the triangle given is a right triangle.
- One angle of the triangle is 20° . The leg opposite this angle is 5 inches long.
 - Find the length of the leg adjacent to the given angle.
 - Find the length of the hypotenuse.
 - One angle of the triangle is 78° . The leg adjacent to this angle is 1 meter long.
 - Find the length of the hypotenuse.
 - Find the length of the leg opposite the given angle.
 - One angle of the triangle is 15.2° . The hypotenuse is 12 centimeters long.
 - Find the length of the leg adjacent to the given angle.
 - Find the length of the leg opposite the given angle.
 - One angle of the triangle is 30.75° . The leg opposite this angle is 5 inches long.
 - Find the length of the leg adjacent to the given angle.
 - Find the length of the hypotenuse.
 - One angle of the triangle is 85.4° . The leg adjacent to this angle is 1.5 miles long.
 - Find the length of the hypotenuse.
 - Find the length of the leg opposite the given angle.
 - One angle of the triangle is 10.2° . The hypotenuse is 3 centimeters long.
 - Find the length of the leg adjacent to the given angle.
 - Find the length of the leg opposite the given angle.
 - A gable is the triangular segment of a wall created by the roof. The pitch of a gable is its height divided by its width. See Figure A.20. (That is, pitch is equal to half the slope of the roof.) Consider a gable 40 feet wide with an angle of 130° at its peak.

3. *New York Times*, October 27, 1996, page 47.

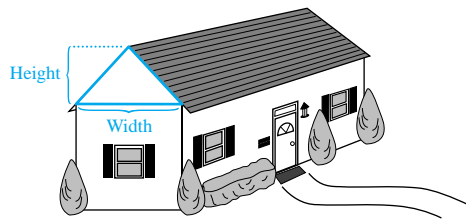

FIGURE A.20

- a. How tall is the attic at its center?
 - b. What is the pitch of the gable?
 - c. How much board would be needed to cover the roof (not including the overhanging portion of the roof) if the house is 40 feet long?
26. Find the diameter of the smallest iron rod from which a hexagonal nut with side 4mm can be cut. (*Hint:* The angle between two adjacent sides of the nut is 120° .)
 27. A stairway is to be constructed on a hill with a 34° incline.
 - a. If each step is to have a 7-inch rise, what must be its tread (horizontal depth)?
 - b. How many 7-inch steps will be needed if the length of the hill (measured up the slope) is 4 feet 2 inches?
 28. A boat that is sailing S 47° E is sailing on a trajectory that is along an angle 47° east of true south. A ship sails 12.8 nautical miles S 47° E from its starting position.
 - a. How far south has the ship sailed?
 - b. How far east has it sailed?
 29. Air Force pilots mark their bearing as the clockwise angle measured from the north. For example, a bearing of 90° is east and a bearing of 180° is south. There is a landing strip 5 miles away from a plane at bearing 332° .
 - a. What bearing is west?
 - b. In what direction must the plane fly to reach the landing strip?

- c. If the plane were to fly directly north or south and then east or west to reach the landing strip, how far in each direction would the plane have to fly?

30. Because the sum of the three angles of any triangle is 180° , a right triangle with one 45° angle must contain another 45° angle. As shown in Figure A.21, this type of triangle is formed by two sides and a diagonal of a square. Thus the two legs of the triangle are of equal length. By the Pythagorean Theorem, the hypotenuse must have length

$$\sqrt{s^2 + s^2} = \sqrt{2s^2} = \sqrt{2}s$$

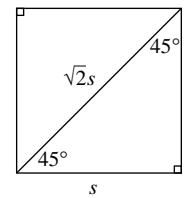

FIGURE A.21

Using the lengths s and $\sqrt{2}s$, determine the exact values of the following trigonometric ratios.

- a. $\sin 45^\circ$
 - b. $\cos 45^\circ$
 - c. $\tan 45^\circ$
31. Use the values for $\sin 45^\circ$ and $\cos 45^\circ$ to determine the sine, cosine, and tangent values of each of the following angles.
 - a. 315°
 - b. -135°
 - c. -225°

For Activities 32 through 39, sketch the given angle on the unit circle, and draw the appropriate right triangle corresponding to this angle. Calculate the sine and cosine of the angle, and indicate these values appropriately on the sketch of the triangle.

32. 160°
 33. 415°
 34. 920°
 35. 310°
 36. -489°
 37. -945°
 38. -280°
 39. -37°
40. Calculate $\sin 180^\circ$ and $\cos 180^\circ$ and explain your answers in terms of the unit circle. Do the same thing for $\sin 90^\circ$ and $\cos 90^\circ$.